

BUSHEY AND DISTRICT MODEL RAILWAY SOCIETY.

Present their

MODEL RAILWAY EXHIBITION

Saturday 26th October 1996
10.30am to 5.00 pm

Upper and Lower Halls
Bushey Hall School
London Road Bushey Watford, Herts.

Layouts in N to gauge 1.
Train rides on 71/4" gauge

Full Trade Support.

Refreshments.

Nearest Station Bushey B.R.

Ample Free Parking - R.A.C. signposted "Bushey Hall School."
Admission Adults £2.50 Children/Senior Citizens £1.00

Members of the Chiltern Model Railway Association.



MKMRS NEWS

No. 55

OCTOBER 1996

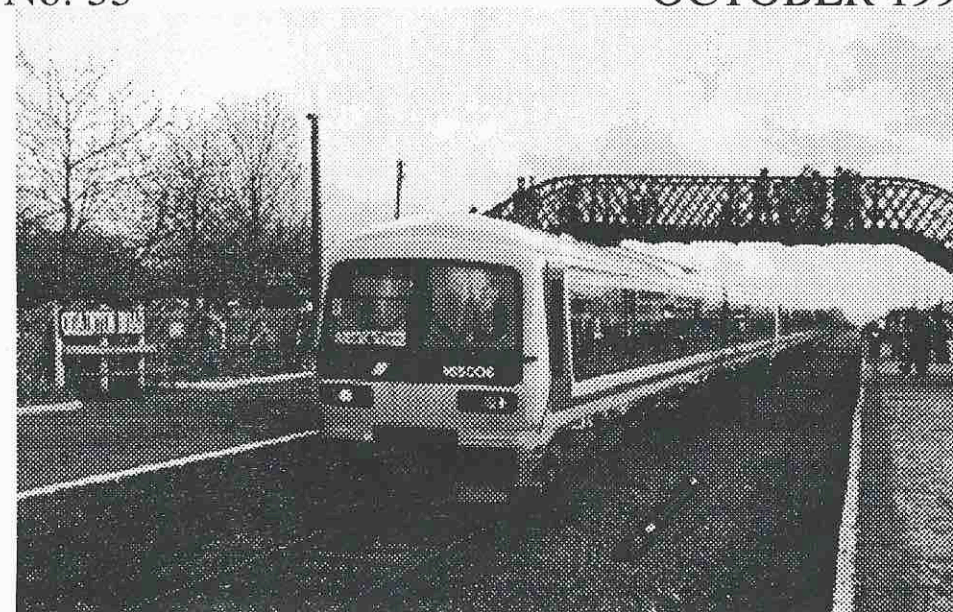

A pair of Chiltern Railways Class 165 Turbo units at
Quanton Road, Easter 1993
Photograph: David Lean

Published by Dennis Lovett, Chairman, Milton Keynes Model
Railway Society.

Telephone 01908 376750

Freight facilities

The gas works at St. Albans were well established long before the arrival of the railway. Once the railway had been completed they became rail served and remained so until they were closed. The works were demolished in 1975 and the site is now occupied by Sainsburys. A goods shed was also provided at St. Albans together with facilities for livestock. During the First World War a large number of injured horses were transported by train to the station where they were taken to the nearby Army veterinary hospital.

Elsewhere on the line, freight facilities were provided to the many factories alongside, at both North Watford and Garston. Most of these were provided between the two world wars (between 1918 and 1939).

At one time a brickworks existed near Bricket Wood and this was rail served until it closed in the 1920s. The works also had its own internal narrow gauge railway system for moving the bricks to and from the kilns.

Bricket Wood had limited freight facilities but included a cattle pen for moving livestock. A siding was also provided at Park Street.

Park Street (& Frogmore)

Park Street station was rebuilt in the 1890s and was moved to a new site, slightly to the north and adjacent to the Watling Street bridge.

At some stage towards the end of the 19th Century, Park Street station was renamed Park Street & Frogmore.

The station reverted to its former name of Park Street in 1974.

The Grouping

In 1923, most of the main railway companies were grouped into 4 larger companies following the passing of the Railways Act 1922. The London & North Western Railway were grouped with the Midland Railway and others to form the London, Midland & Scottish Railway (The LMS). This company now owned two of the stations in St. Albans and in order to differentiate between the two, in 1924, the main station became City and the station on the line from Watford was renamed St. Albans Abbey.

In 1939 the LMS was the largest private company in the world with:

19,000	track miles
250,000	staff
25	docks and harbours
66	ships
4,000	vehicles
8,000	horses
28	hotels
25,000	houses
500	miles of canal

The LMS also had extensive interests in air services, warehousing, engineering, removals, farming and gas supply. By today's standards, it was a very large company indeed.

Nationalisation

Following the passing of the Railways Act 1947, the four main railway companies were nationalised and passed from private ownership into the public sector. They became part of the British Transport Commission and traded under the name British Railways (BR). In 1965 this name was shortened to British Rail (BR).

To be continued

MILTON KEYNES MODEL RAILWAY SOCIETY

Founded 1969

President	Jim Wood	Committee	Geoff Bell
Vice Presidents	Les Wood		Chris Garner
	Gordon Etherington		Chris Lester
Chairman	Dennis Lovett		Colin Jamieson
Vice Chairman	Fred Collins	Librarian	Mark Wilson
Secretary	Chris Hughes	Museum Co-ord.	John Hatton
Treasurer	Eric Bowman	CMRA Rep.	Chris Lester

MKMRS is a member of the Chiltern Model Railway Association and the Model Railway Club.

From Bletchley to Norfolk

The announcement that Bletchley Railwayana is to leave St. Mary's Avenue and move to Norfolk will leave us once again without a major model railway shop in the town.

I find it amazing that in town where 50% of the shops stand empty, a successful business has been forced to move elsewhere because of the heavy increase in rents proposed by the owners - the local authority!!

Gordon has been a good friend to the club and has allowed us generous discounts on items for many of the projects now taking place. He has been an active member over many years and we wish Gordon and Brenda well in their move to the seaside.

The lure of steam and a site on one of the country's premier steam railways is too good an offer to miss - particularly as the rents are far lower than in this part of the world.

Many of us have become used to having a good local model shop. The period from the demise of Rails to the setting up of Gordon's business was bad enough. Now we shall have to go further afield. Fortunately Gordon will be able to offer a good mail order service, but it is not the same as "popping up the road".

Model Shops are now becoming a rare commodity in many towns and cities. I have lamented in the past the loss of well known train suppliers in the immediate area. London, with the closure of Puffers is down to a mere handful of shops, now confined to the outer suburbs rather than high profile sites in the middle.

There are always swapmeets, but I would take a long hard look before I spent serious money on the items on offer, particularly locomotives. The number of repairs which appeared on Monday mornings at St. Mary's Avenue after a swapmeet only had to be seen to be believed!

Toy shops are today noticeable for the lack of model railway items. Go into large high street toy shop and see what I mean!

Model railways are fast becoming less of a toy and aim for the adult collector. The result is a declining market and I wonder how long it will be before the many model railway magazines seen on display in newsagents command less shelf space.

The loss of Bletchley Railwayana will produce a void, we shall no longer have a place where we can enrol new members, many of whom live locally yet have never heard of MKMRS!

Our loss is Norfolk's gain. I wish Gordon every success with his new business venture - GE Models. Yes - the change of venue means a change of name! You can't have Bletchley Railwayana in Sheringham can you?

Dennis Lovett, Chairman

Club notes

Swapmeet dates

A swapmeet will take place at Woughton Campus on the following dates during 1996;

13th October
8th December

Opening times are 1100 - 1500. Admission is 70p, child/senior citizens 30p

Gauge O Guild - Spring Convention 8th March 1997

The Gauge O Guild will be returning to Bletchley Leisure Centre after a gap of a couple of years for their Spring Convention - next March.

We have almost a years notice to round up volunteers for stewarding etc. We have also been asked to provide catering and to assist with the setting up on the Friday evening (7th March 1997).

Please book these dates in your diary a.s.a.p Please note this is a **one day show** (mainly trade with some supporting layouts).

Gordon Etherington, Vice President

The Scale Show - 19th October

The S Scale Model Railway Society has invited MKMRS to provide 12 (or more) stewards at its 50th Anniversary event. The S Scale Society is a small organisation of talented scratchbuilders who work at 3/16 inch to 1 Foot. Our Honourary Member Ian Pusey, is also Chairman of the S Scale Society and it is

important that we support Ian at this event, who after all has done us proud on many occasions in the past. The 2mm Association are also providing exhibits and they too are a specialist group, who scratchbuild many of their models.

This looks to be an excellent show and the organisers have promised not only free entry to those volunteering to Steward but lunch as well from the Leisure Centre caterers.

Volunteers please put your name on the list by the signing in book. Tim Davey, Eric Bowman, Dennis Lovett, Ernie Johnson, Chris Lester and Ken James have already volunteered and I look forward to supplying Ian with a long list in due course.

Dennis Lovett, Chairman

Woburn Sands Show

Colin Jamieson is looking for volunteers to assist with this one day event at Woburn Sands on 21st September. Please see Colin Jamieson a.s.a.p.

HMRS return

The HMRS will be at the club rooms on Wednesday 28th September when the speaker will be _____ covering the Highland Railway. Meetings commence at 7.30 pm and MKMRS members are welcome to attend.

Bletchley Park duties

The Bletchley Park duty roster now appears on Page 3. Your support is greatly appreciated. John Hatton will explain the procedures and how to operate layouts.

Additional volunteers are needed over the 3 day August bank holiday weekend.

NB - not opening 21st Sept. (Woburn Sands event)

Club notes extra

Rolling stock

Some items of rolling stock and other items stored on layouts and elsewhere has recently been mislaid. Anyone with information to their current whereabouts is invited to reveal all. Some items recently mislaid turned up in one of our recent tidy-up sessions, so we shall no doubt find the other items as well!

Please advise me if they have turned up in the area used by your specific projects.

Dennis Lovett
Chairman.

QGM

The next QGM will be held on **Tuesday 29th October** starting at 8pm in the club room.

Would Committee members and club officers please note that a Committee Meeting will be held in the club room on Wednesday 23rd October commencing at 7.45pm.

Steam on the Bedford line

We understand that the Bedford - Bletchley 150th Anniversary committee will be sponsoring steam trains on the Bletchley - Bedford (Marston Vale Line) on Saturday 21st December. Further details will appear when known.

Fenny Stratfords first outing to Fenny Stratford

The Fenny Stratford layout will make its first public appearance at St. Martin's Church open weekend on 14th / 15th September. This is to enable the layout to be moved

and tested before it's first appearance at the Woburn Sands event, the following weekend.

Stacey Hill Museum Transport Open Day

John Hatton will be attending the event on Sunday 15th September with his Trix Twin layout.

Stan and Brian will also be present with their vintage layout. This is the first transport day to be held since the serious fire last winter gutted many of the exhibits and is worthy of our support.

Stop press - Scale Show

In order to include information on the Scale Show (October 19th - see page 2), Part 5 on the British Pacific series has had to be held over until the next issue.

The Scale Show looks to be well worth visiting. Stewards are still needed - details from the Chairman.

The Abbey Branch (Part 3) by Dennis Lovett

All the fun of the fair

Bricket Wood had established itself from the opening of the line as a pleasant place to visit for walking and enjoying the fresh air. By the 1890's, it had become a popular venue for Sunday School and other outings and a considerable number of excursion trains

were operated to cope with the demand.

In 1899, Grays opened a fun fair at Bricket Wood and traffic increased accordingly. In 1904, a miniature railway was added to the list of attractions. This had a track gauge of 10 1/4", which is still popular today in sea-

side towns, theme parks and other attractions. A miniature railway operates in Cassiobury Park, Watford today.

The increase in traffic required construction of an additional platform for use by excursion trains only. This work was completed in August 1913.

Bletchley Park Roster Board

By the Chief Roster Clerk

January 13th: JH, Fred Collins, Ernie Johnson	July 13th: JH, Don Pigott, Eric Preston
January 14th: JH, Ray/Richard Cousins, John Tennant	July 14th: JH, Roger Blackburn
January 27th: JH, Richard Cousins	July 27th: Colin Jamieson & Peter Moore
January 28th: JH, John Tennant	July 28th: Tony Cordwell
February 10th: Bruce Garwood, Ken James	August 10th: JH, Tony Cordwell
February 11th: JH, Chris & Nick Hughes	August 11th: JH, John Tennant Dennis Lovett,
February 24th: JH, Dennis Lovett, John Tennant	August 24th: JH, John Tennant, Eric Preston, Chris Lester
February 25th: Chris Garner, Ken James	August 25th: JH, John Tennant, Bruce Garwood, John Dibben, Ken James
March 9th: JH, Geoff Bell	August 26th: JH, John Tennant, Ernie Johnson, Dennis Lovett
March 10th: JH, Dennis Lovett	
March 23rd: Tim Davey, Ken James	September 7th: JH, Ernie Johnson
March 24th: Chris Hughes	September 8th: JH, Bernard Worden
April 6th: JH, Ernie Johnson	September 21st: Woburn Sands Event (not opening)
April 7th: JH, Bernard Worden	September 22nd: Dennis Lovett, Les Wood
April 20th: Eric Bowman, Gordon Shrimpton	October 5th: JH, Tony Winn
April 21st: Richard & Ray Cousins	October 6th: Ray & Richard Cousins
May 4th: John Tennant, Chris Hughes	October 19th: TBA (S Scale/2mm Association, BLC)
May 5th: John Tennant Roger Blackburn	October 20th: JH, Gordon Shrimpton
May 6th: John Tennant Chris Lester	November 2nd: Geoff Bell, Colin Jamieson
	November 3rd: JH, Fred Collins
May 18th: Bruce Garwood & Ken Wiggins	November 16th: Ken James
May 19th: JH, Fred Collins, John Tennant	November 17th: Chris Hughes
June 1st: JH, Tony Winn	November 30th: Ken James
June 2nd: JH, Dennis Lovett	December 1st: Don Pigott, Eric Preston
June 8th: JH, Mark Wilson	December 14th: Chris Lester, Phil Gilbert
June 9th: JH, Bruce Garwood, Ken Wiggins, John Tennant	December 15th: Chris Garner, Ken Wiggins
June 15th: Gordon Shrimpton, Les Wood	
June 16th: Chris Hughes, John Tennant	
June 29th: Richard & Ray Cousins	
June 30th: JH, Chris Garner, John Tennant	

JH = John Hatton (Museum co-ordinator).

If you are unable to work the day allocated please arrange a "swop" with another

MODEL RAILWAYS IN S & 2MM SCALES

The Scale Show

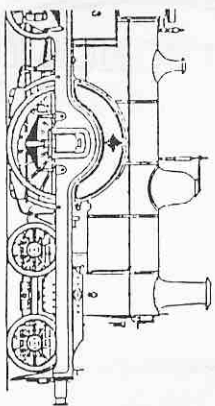

Bletchley - October 19th 1996

PRINCES WAY - BLETCHLEY - MILTON KEYNES
LEISURE CENTRE

Bletchley main line station is a short walk or exit M1 Junc 13-14
Admission £4.00 including guide

Open 10.30 to 5.00
Admits 1 adult + 1 child



For more information write to 5 Park Place, Wembley Hill, Middx HA9 8DB

*real historical railway crests
layouts - models
demonstrations
trade stands*

*layouts to include
2mm scale*

Copenhagen Fields
Burnham-on-Sea
Chipping Norton
Inversnecky
Ashburton
S scale
Emwell
Yaxbury
East Lynn
Eagle Lake
Lydham Heath
other scale layouts
3mm (14.2mm) Hemlock EM Watford Town
S4 Wanborough Camp 7mm Ditchling Green
ALSO - early commercial models in 2mm & S scale

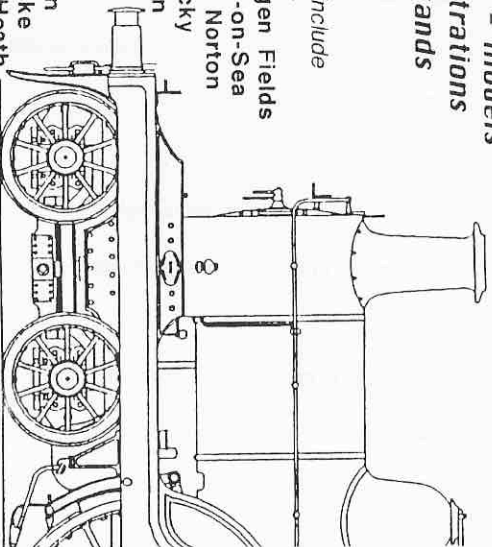

S scale 50

The S Scale Model Railway Society
celebrating the oldest scale society's 50th birthday
in partnership with
Expo 2mm
Of The 2mm Scale Association





MODEL RAILWAY EXHIBITION

Saturday 21st September

**Fullbrook School, Weathercock Lane
WOBURN SANDS**

*** WORKING MODEL RAILWAY LAYOUTS * SOCIETY STANDS**

*** VINTAGE BUS FROM WOBURN SANDS STATION**

*** REFRESHMENTS**

10:30 am - 4:30 pm Adults £1 Children 75p

Travel by train to Woburn Sands during the 150th Anniversary year of the Bedford to Bletchley Railway line



WE ARE MOVING (TO NORFOLK)

Bletchley Railwayana is moving lock, stock and loco from its present base to the North Norfolk Railway at Sheringham Station.

Unfortunately this will mean the closure of the existing business as I have been unable to renew the lease on the existing premises. Obtaining suitable replacement premises in the Milton Keynes area was proving difficult, when my attention was drawn to the opportunities that exist at Sheringham. I would like to thank my customers in Milton Keynes for their past support and hope that I can continue to serve many of you in future.

The actual closure date of this shop will be announced later. The new shop will require a change in trading name and the business will operate as G E Models on relocation to Platform 3 at Sheringham station.

Mail order has become an increasingly important part of the business and I hope to continue to provide many of my Milton Keynes area customers by mail order from Norfolk.

I would like to thank my customers in Milton Keynes for their past support and hope that I can continue to serve you in future. I look forward to seeing many of you in Norfolk.

Gordon Eckersley